

## IRRIGATION MAINTENANCE

### Description

- ▶ Final Drive Gearbox Maintenance Procedures
- ▶ Spur Gear Center Drive Maintenance Procedures
- ▶ Worm Gear Center Drive Maintenance Procedures
- ▶ C-Face Motor Maintenance Procedures
- ▶ Towable Hub Assembly Maintenance Procedures
- ▶ Drive Line Coupler Maintenance Procedures

THE FOLLOWING MAINTENANCE PROCEDURES MUST BE PERFORMED OR THE DRIVE TRAIN WARRANTY WILL BE VOID.

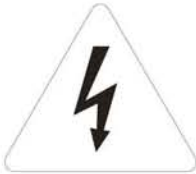

## WARNING



- TO REDUCE THE POTENTIAL OF A SEVERE ELECTRICAL SHOCK AND TO PREVENT BODILY INJURY FROM SUDDEN STARTUP OF THE MOTOR, ALWAYS DISCONNECT ALL ELECTRICAL POWER SOURCES BEFORE INITIATING ANY MAINTENANCE OR REPAIRS.
- ALWAYS BE SURE THAT YOUR BODY IS DRY AND THAT THE GROUND UNDER YOUR FEET IS DRY BEFORE TOUCHING THE MOTOR OR ANY OTHER ELECTRICAL EQUIPMENT ON THE MACHINE. FAILURE TO HEED THIS WARNING MAY CAUSE PERSONAL INJURY DUE TO SEVERE ELECTRICAL SHOCK.

THE FINAL DRIVE WHEEL GEARBOX, THE SPUR GEAR CENTER DRIVE GEARBOX, THE WORM CENTER DRIVE GEARBOX, THE C-FACE MOTOR, THE BOLT ON TOWABLE HUB AND THE DRIVE LINE COUPLERS REQUIRE PERIODIC, YEARLY AND IN-SEASON MAINTENANCE. PLEASE REFER TO THE FOLLOWING SERVICE INFORMATION FOR THE ABOVE ITEMS.

IF YOU SHOULD HAVE ANY QUESTIONS, PLEASE CALL YOUR LOCAL DEALER.

**A. THE FINAL DRIVE GEARBOX MUST BE SERVICED AS FOLLOWS AFTER EACH CROP CYCLE, A MINIMUM OF ONCE A YEAR.  
SEE SECTION "V" "TOW HUB MAINTENANCE" FOR 725-UT TOWABLE GEARBOXES.  
SEE SECTION "D" AND "E" FOR ADDITIONAL REQUIREMENTS FOR TNT AND 760 MODELS.**

1. Inspect input and output shaft seals for leakage. Should either the input or output shaft seals show excessive leakage, the seals should be replaced. All replaced seals must be installed with generous amounts of #2 Barium/Lithium base grease (or use equivalent quality #2 water resistant grease) on the seal lips.
2. External (dust exclusion) seals should be used to keep dirt and water out of internal seal locations. If the external seals are damaged or worn, replace with new seals. Note that there are several different types of seals available.
3. The seal drain hole (on 720 and previous models and on 725 units shipped before October 1996) located on both input caps must be kept clear of dirt. Clear the hole using a 12-gauge wire, a nail or a punch. Lightly rotate the tool to loosen and remove dirt. **CAUTION, DO NOT DAMAGE THE SEAL CASE OR LIPS.** See Diagram FD-1.
4. The vent hole located on the side of the Expansion Chamber must be kept clear of dirt. Use a soft brush to clear the opening. **DO NOT INSERT ANY OBJECTS INTO THE VENT HOLE, DAMAGE TO THE RUBBER DIAPHRAGM MAY OCCUR.**

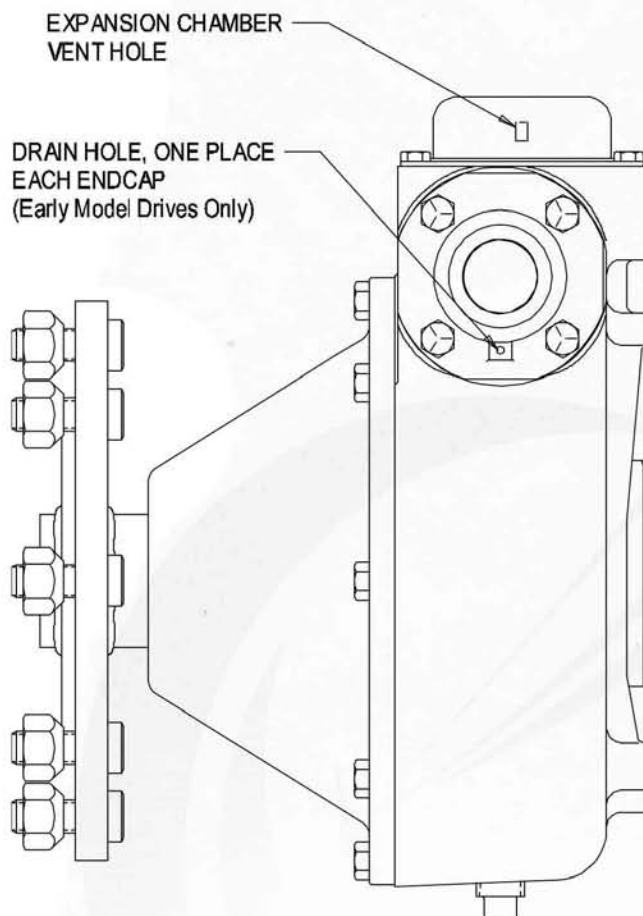

DIAGRAM FD-1



## FINAL DRIVE GEARBOX MAINTENANCE PROCEDURES

5. Each input shaft should be checked for excessive endplay after each crop cycle, this is done by disconnecting the drive-line coupler & tapping the input shaft on both sides with a dead blow hammer or mallet. If any axial endplay is present, input shims should be installed to eliminate the endplay.
6. Inspect the Hub Cap (Shaft Guard), on the unused side of the input shaft, for looseness, damage or corrosion. Replace if necessary or if it is missing. This will protect the input shaft and seals from the elements.
7. All 3/8-16 cover and end cap bolt torque should be 28-31 ft. lbs.
8. All 9/18-18-wheel lug nut torque should be 115-120 ft. lbs.
9. Remove the plug located at bottom of the gearbox and completely drain the gearbox oil. If the oil is contaminated or emulsified, flush the gearbox with a cup of specified oil and let it drain completely.
10. Replace the drain plug at the bottom of the gearbox. Fill the gearbox with the proper oil, through the top fill hole, to the operating oil level range. The oil level range is from the top of the Worm shank (next to the bearing cone) to the bottom of the oil fill hole (at 70• F ambient temperature) as shown in Diagram FD-2. Refer to oil specification.

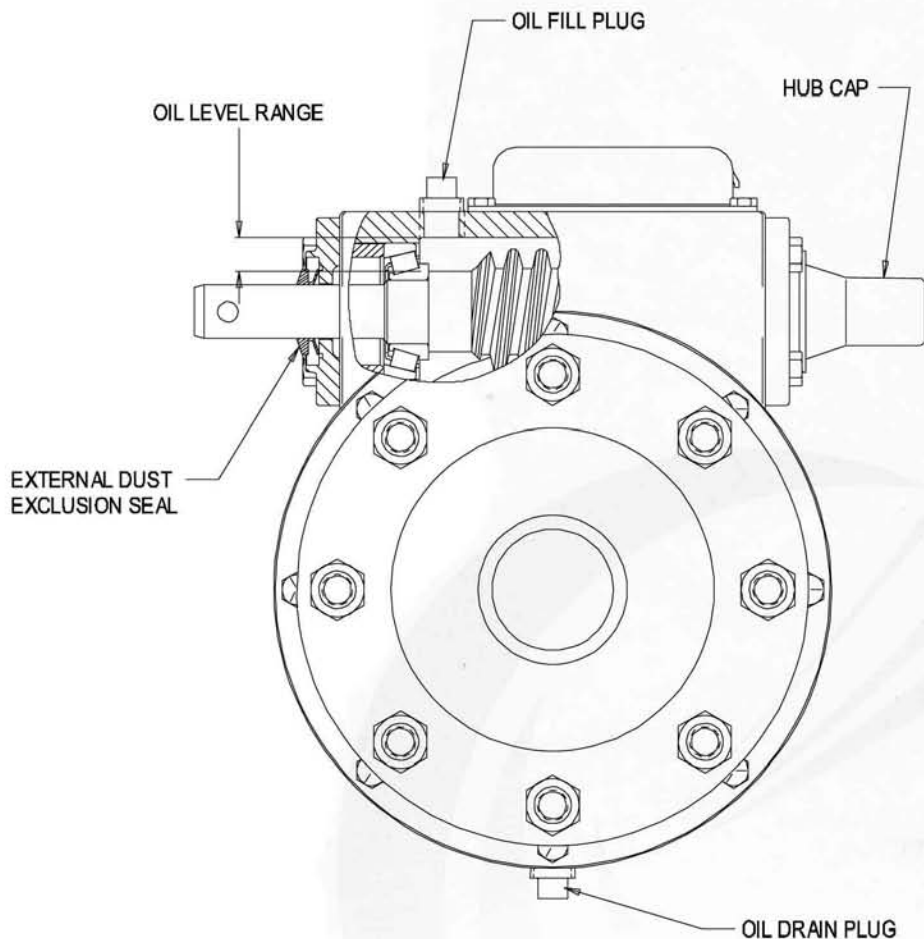

DIAGRAM FD-2

**B. FINAL DRIVE GEARBOX LUBRICANTS**  
**SEE SECTION “V” “TOW HUB MAINTENANCE” FOR 725-UT TOWABLE GEARBOXES.**

A GL-5 SAE 85-140, MIL-C-2105, ISO 460, AGMA 7EP or equivalent gear lube must be used in final drive gearboxes. Some common brands meeting this specification are shown below. Contact your dealer or local petroleum product distributor for other equivalent products. Use of improper oil will void the gearbox warranty.

- \* Hector S-150 Philube 1-LB Gear Oil #140
- \* Chevron Gear Compound #140
- \* Valvoline 85-140 Gear Oil
- \* Mobil Gear 85-140
- \* Pennzoil 85-140
- \* Texaco Multigear Lubricant EP SAE 85W-140

Oil capacity 1 U.S. gallon approximately

**C. IN-SEASON FINAL DRIVE GEARBOX MAINTENANCE**  
**SEE SECTION “V” “TOW HUB MAINTENANCE” FOR 725-UT TOWABLE GEARBOXES.**

The final drive gearboxes should be inspected periodically during the operating season, for the following:

1. The proper oil level should be maintained at all times. See Diagram FD-2.
2. Contaminated or emulsified oil should be replaced with new oil.
3. Input seal drain holes on the final drive gearbox should be kept clear. See Diagram FD-1.
4. Expansion chamber vent hole should be kept clear. **CAUTION, DO NOT INSERT ANY OBJECT INTO THE HOLE, DAMAGE MAY OCCUR TO THE RUBBER DIAPHRAGM.**
5. Input & output shaft seals should be inspected for excessive leaks and replaced if necessary.
6. **FAILURE TO MAINTAIN GEARBOXES AS SPECIFIED WILL VOID THE GEARBOX WARRANTY.**

**D. TNT Models are supplied with grease fittings located on the top of the gearbox (see fig. On the next page) for lubricating the bale assembly. Use a #2 lithium grease at initial installation and depending of frequency of towing once or twice per season. Actuate the handle a few times to distribute grease after lubrication.**

**E. The 760 Heavy duty model gearbox is supplied with three grease fittings. Two are located on the top of the gearbox and the third is located at the output shaft position. (see fig. On the next page) These fittings are provided to extend the seal life and should lubricated once per season and at initial installation with #2 lithium grease. NOTE use a small amount of grease as the seal lips will not allow excess grease to exit the box but be forced inside.**



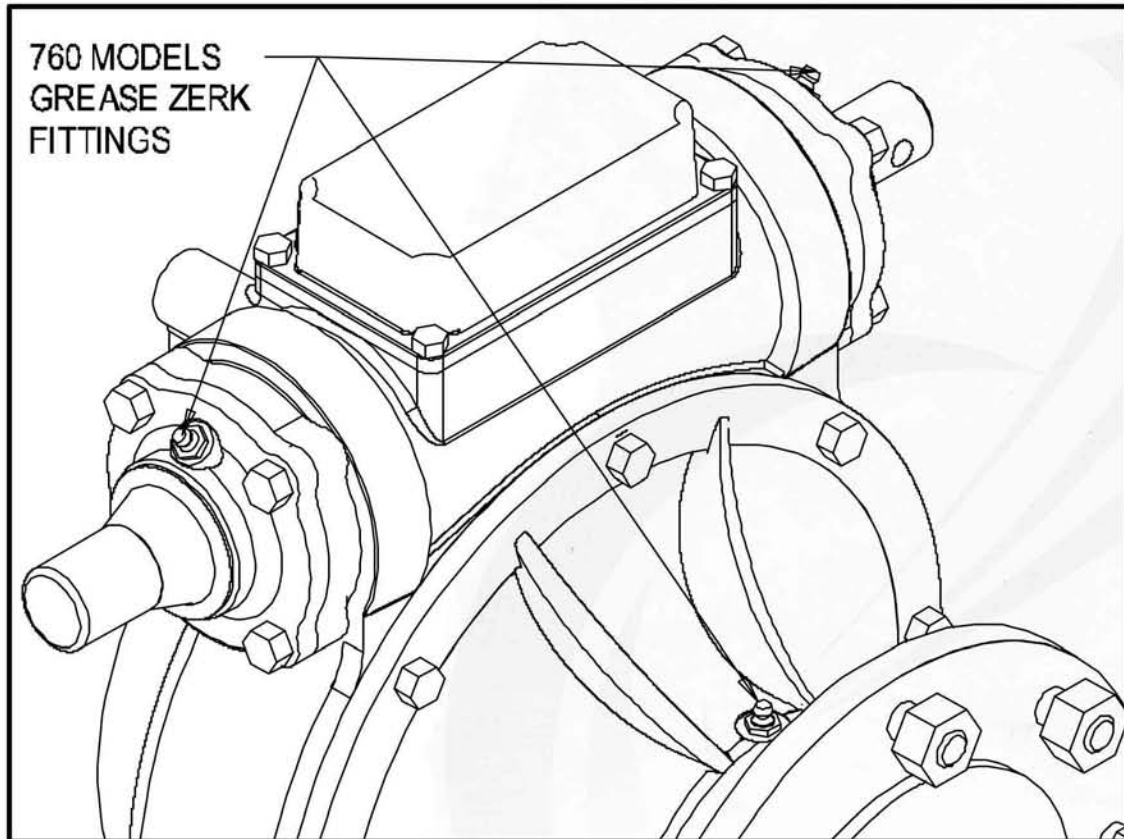
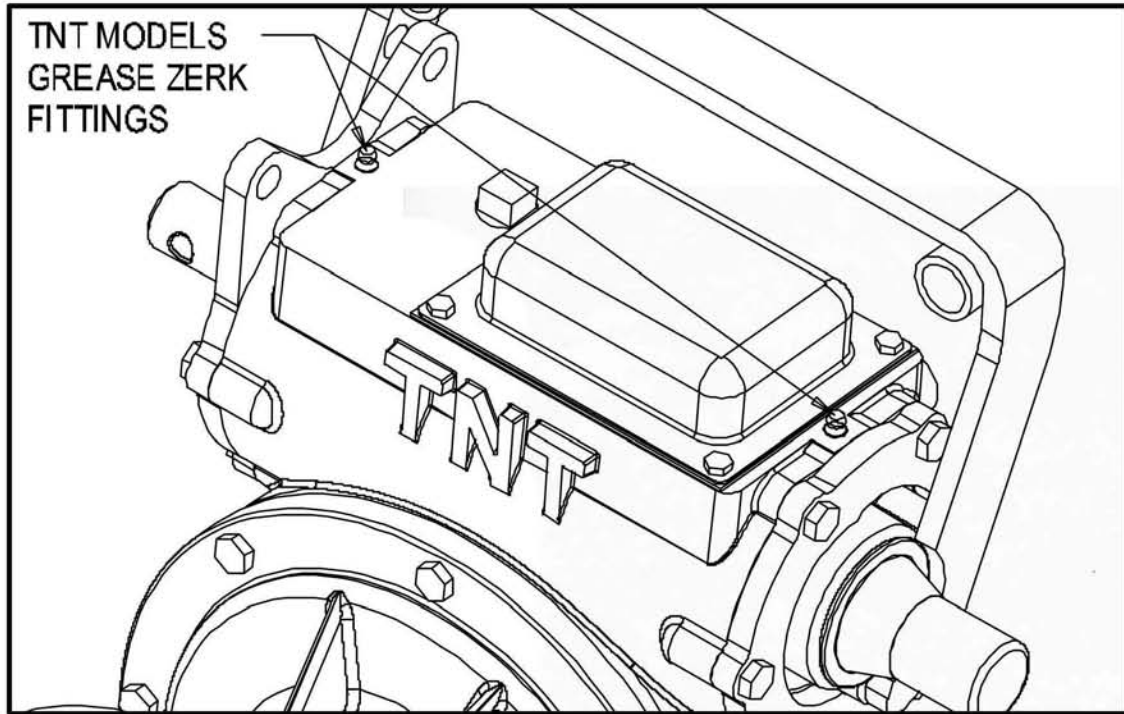



## WARNING



- To reduce the potential of a severe electrical shock and to prevent bodily injury from sudden startup of the motor, always disconnect all electrical power sources before initiating any maintenance or repairs.

### A. THE SPUR GEAR CENTER DRIVE MUST BE SERVICED AS FOLLOWS AFTER EACH CROP CYCLE, A MINIMUM OF ONCE A YEAR.

1. Inspect output oil seals for leakage. Should either of the seals show excessive leakage, the seals should be replaced. All replaced seals must be installed with generous amounts of #2 Barium/Lithium base grease (or equivalent type #2 water resistant grease) on the seal lips.
2. External dust exclusion seals should be used to keep dirt and water out of internal seal locations. If the external seals are damaged or worn, replace with new seals.
3. The two (2) drain holes located under the motor-can must be kept clear to allow for drainage of accumulated moisture inside the motor. If any oil is found weeping out of the water drain holes, remove the motor stator and inspect the rotor seal for leakage. Replace the seals same as step 1 above. **DO NOT OPERATE THE UNIT WITHOUT INSPECTING THE ROTOR SEAL, A SEVERE ELECTRIC SHORT MAY OCCUR IF THE PROBLEM IS NOT CORRECTED.** Diagram SG-1.
4. The two (2) drain holes located under the endbell must be kept clear to allow for drainage of accumulated moisture inside of the junction box. Diagram SG-1.

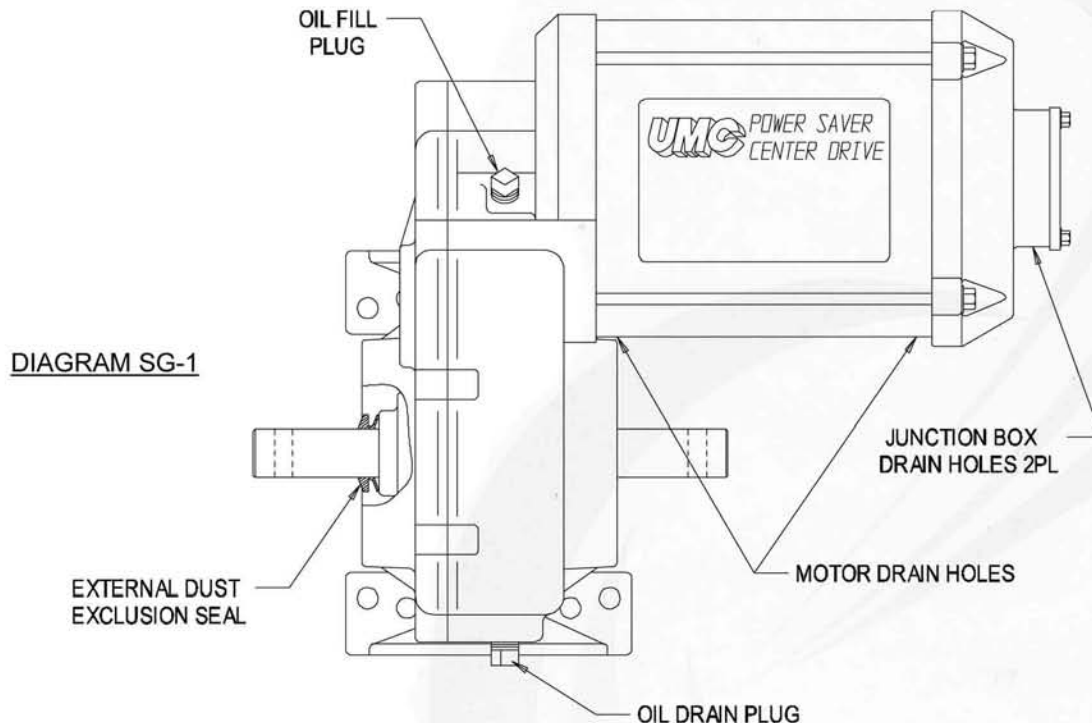

5. Remove the drain plug located at bottom of the gearbox and completely drain the gearbox oil. If the oil is contaminated or emulsified, flush the gearbox with a cup of specified oil and let it drain completely.

6. Replace the drain plug and refill until the oil (at 70°F ambient temperature) reaches the threads on the oil fill hole. See Diagram SG-2 for the oil level range at the bench top and at the pivot-mounted position. Refer to oil specification.

DIAGRAM SG-2

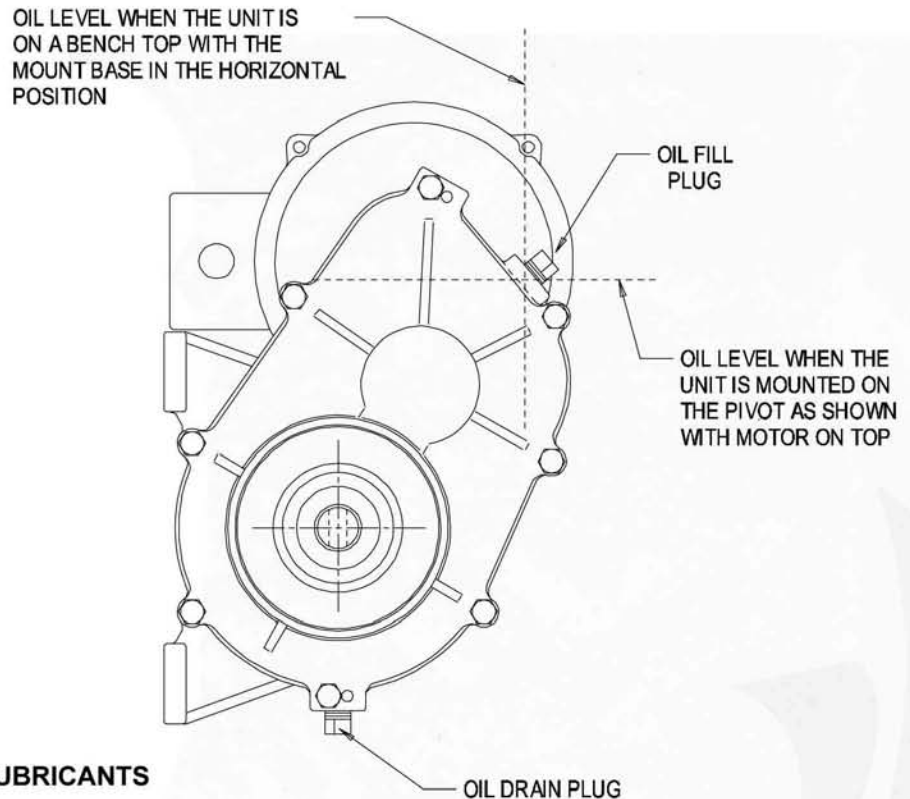

### **B. SPUR GEAR CENTER DRIVE LUBRICANTS**

1. Use SAE 50W, or SAE 20W-50 multi viscosity engine oil. Use ISO 460 or EP 460 gear oil. Use of improper oil will void the gearbox warranty.
2. Oil capacity is 0.4 U.S. Gallons or 1.6 Liters approximately.

### **C. IN-SEASON SPUR GEAR CENTER DRIVE MAINTENANCE**

The spur gear center drive gearboxes should be inspected periodically during the operating season.

1. The proper oil level should be maintained at all times. See Diagram SG-2.
2. Contaminated or emulsified oil should be replaced with new oil.
3. Input & output shaft seals should be inspected for excessive leaks and replaced if necessary. Check motor can drain holes for oil. See step 2 in section A above.
4. Motor can and junction box drain holes must be kept clear so that any moisture can drain out. See Diagram SG-1.
5. **FAILURE TO MAINTAIN THE CENTER DRIVE AS SPECIFIED WILL VOID THE CENTER DRIVE WARRANTY.**



**A. THE WORM GEAR CENTER DRIVE MUST BE SERVICED AS FOLLOWS AFTER EACH CROP CYCLE. MINIMUM ONCE A YEAR.**

1. Inspect input and output shaft seals for leakage. Should either the input or output shaft seals show excessive leakage, the seals should be replaced. All replaced seals must be installed with generous amounts of #2 Barium/Lithium base grease (or equivalent quality #2 water resistant grease) on the seal lips.
2. External seal protectors should be used to keep dirt and water out of internal seal locations. If the external seals are damaged or worn, replace with new seals.
3. The flange drain holes (5 places) located under the motor mount flange must be clear. Clear the hole with a 12-gauge wire, nail or punch by rotating in the hole to loosen and remove dirt. See Diagram WG-1.

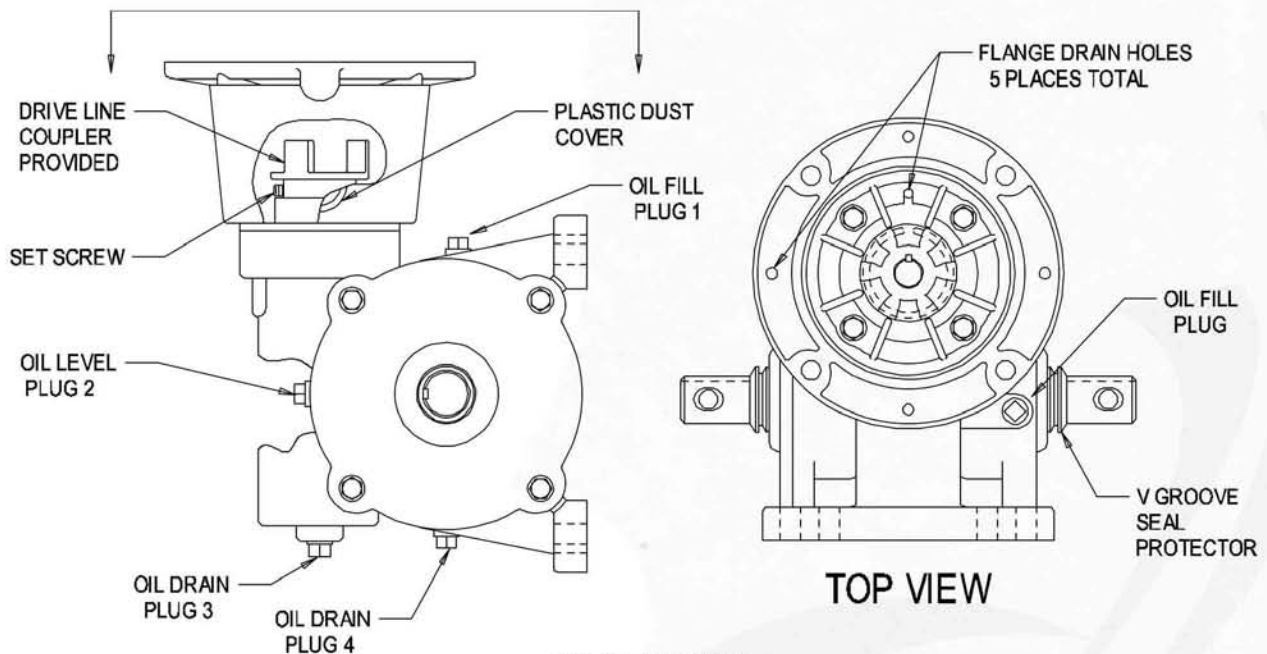

DIAGRAM WG-1

4. All 5/16-18 cover bolts and internal flange bolts should be torqued to 13-15 ft-lbs.
5. Remove the drain plugs located at bottom of worm (#3) and on the bottom of housing (#4) and drain the gearbox oil. If the oil is contaminated or emulsified, flush gearbox with a cup of specified oil and let it drain completely. See Diagram WG-1.
6. Replace the drain plugs and refill the gearbox with oil (at 70• F ambient temperature) through the oil fill hole (#1) to the proper operating level (mid worm gear at plug #2) as shown in Diagram WG-1. Refer to the oil specification.

### **B. WORM GEAR CENTER DRIVE GEARBOX LUBRICANTS**

A ISO 460 or AGMA 7EP gear lube must be used in worm gear center drive gearboxes. Some common brands meeting this specification are listed in section B of Final Drive Gearbox.

Oil capacity 3 1/2 U.S. pints approximately

### **C. IN-SEASON WORM GEAR CENTER DRIVE MAINTENANCE.**

The spur gear center drive gearboxes should be inspected periodically during the operating season.

1. Proper oil level (mid worm gear at plug #2 on Drawing WG-1) should be maintained at all times.
2. Contaminated or emulsified oil should be replaced with new oil.
3. Input and output shaft seals should be inspected for excessive leaks and should be replaced if necessary.
4. **FAILURE TO MAINTAIN GEARBOXES AS SPECIFIED WILL VOID THE GEARBOX WARRANTY.**



## WARNING



- To reduce the potential of a severe electrical shock and to prevent bodily injury from sudden startup of the motor, always disconnect all electrical power sources before initiating any maintenance or repairs.

**A. THE C-FACE MOTOR MUST BE SERVICED AS FOLLOWS AFTER EACH CROP CYCLE, A MINIMUM OF ONCE A YEAR.**

1. Check all bolts for looseness. Tighten as required.
2. Check the seal tight connector into the junction box for looseness or damage.
3. The three (3) drain holes located under the motor junction box should be kept clear to allow for drainage of accumulated moisture inside the motor junction box.

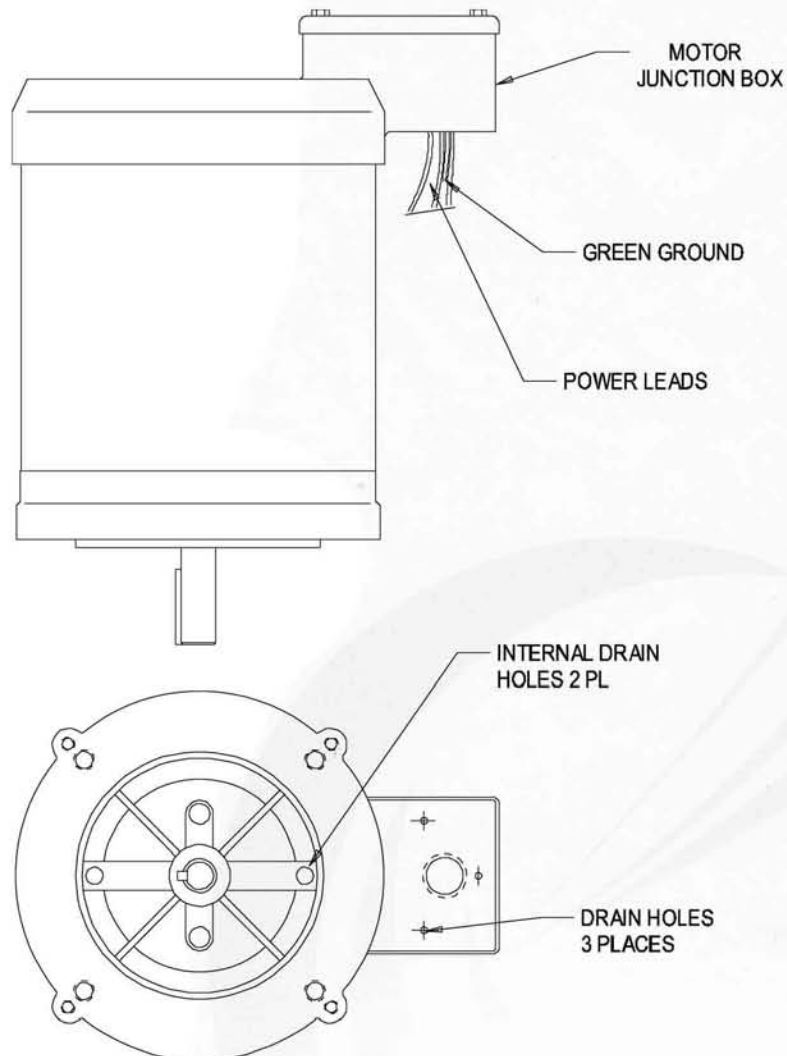



- A. **THE BT-4, BT-4B AND 725-UT TOWABLE HUB ASSEMBLY'S MUST BE SERVICED AFTER EACH CROP CYCLE, A MINIMUM OF ONCE A YEAR.**
1. Remove the bolt on hubcap and check for contaminants such as dirt, water, etc. If no contaminants are found, proceed to step 3 below. If any contaminants are found, completely disassemble and inspect the seal & bearings. Replace as required.
  2. Re-assemble the unit. Pack the bearings & seal lips with the appropriate grease type listed below. The SAE lock nut must be tightened to achieve a hub turning torque of 45-60 in-lbs. Install the hubcap using RTV sealer and torque the ¼-20 screws to 6-8 ft.lbs. Proceed to step 4 below.
  3. Towable hub should be checked to determine no bearing play (low bearing pre-load) is present. Check for proper bearing pre-load by rocking tire back and forth to determine play. If any bearing play is observed, the SAE lock nut must be tightened to achieve a hub turning torque of 45-60 in-lbs. Install the hubcap using RTV sealer and torque the ¼-20 screws to 6-8 ft.lbs.
  4. Towable hub should be greased with #2 Barium/Lithium grease or equivalent quality #2 water resistant grease. Fill at the grease fitting until the stem of the fill indicator (relief on the opposite side) is raised approximately 0.125". **DO NOT OVER FILL, OVERFILLING MAY CAUSE SEAL DAMAGE.** Diagram BT-1.
  5. All 9/16-18 lug nuts should be torqued to 115-120 ft. lbs.

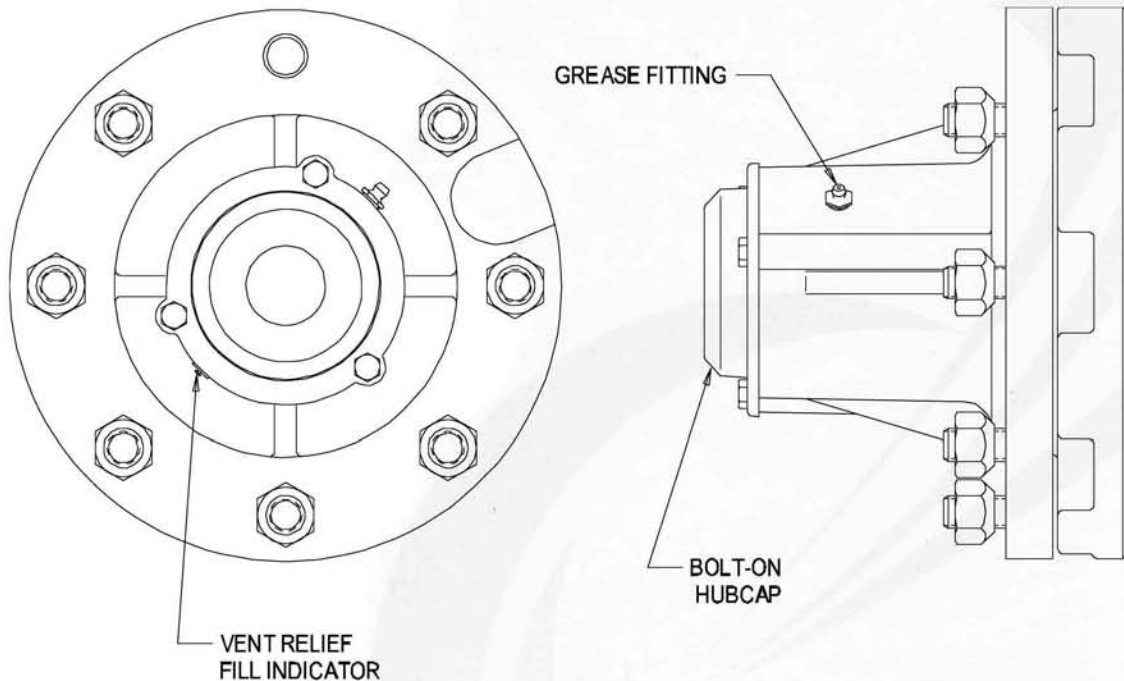

DIAGRAM T-1 – for BT-4, BT-4B and 725-UT  
(note- 725-UT not shown)

### **B. IN-SEASON BT-4, BT-4B AND 725-UT TOWABLE HUB ASSEMBLY MAINTENANCE.**

The towable hub assemblies should be inspected periodically during the operating season.

1. Check for proper bearing pre-load by rocking tire back and forth to determine play. See step 3 in the section above.
2. Damaged, loose or missing bolt on hub caps.
3. **FAILURE TO MAINTAIN THE UNIT AS SPECIFIED WILL VOID THE UNIT WARRANTY.**

### **C. THE BT-3 TOWABLE HUB ASSEMBLY MUST BE SERVICED AFTER EACH CROP CYCLE, A MINIMUM OF ONCE A YEAR.**

1. Towable hub should be greased with #2 Barium/Lithium grease or equivalent quality #2 water resistant grease. Fill at the grease fitting until the stem of the fill indicator (relief on the opposite side) is raised approximately 0.125". **DO NOT OVER FILL, OVERFILLING MAY CAUSE SEAL DAMAGE.** Diagram BT-1.
2. All 9/16-18 lug nuts should be torqued to 115-120 ft. lbs.
3. Towable hub should be checked to determine no bearing play (low bearing pre-load) is present. Check for proper bearing pre-load by rocking tire back and forth to determine play. If any bearing play is observed, the Towable hub must be shimmed to achieve a hub turning torque of 25-50 in-lbs.

### **D. IN-SEASON BT-3 TOWABLE HUB ASSEMBLY MAINTENANCE.**

The towable hub assemblies should be inspected periodically during the operating season.

1. Check for proper bearing pre-load by rocking tire back and forth to determine play. See step 3 in the section above.
2. Damaged, loose or missing hub caps.
3. **FAILURE TO MAINTAIN THE UNIT AS SPECIFIED WILL VOID THE UNIT WARRANTY.**

**E. SEAL REPLACEMENT – BT-3, BT-4 & BT-4B BOLT-ON TOWABLE UNITS.**

The seal on the “BT” units was changed to a “Thick Lip Grease Seal” (no metal spring) starting in late 1998. The previous seal was a “Spring Backed Oil Seal”. The seals are to be installed as shown below, **FAILURE TO DUE SO WILL VOID THE WARRANTY.**

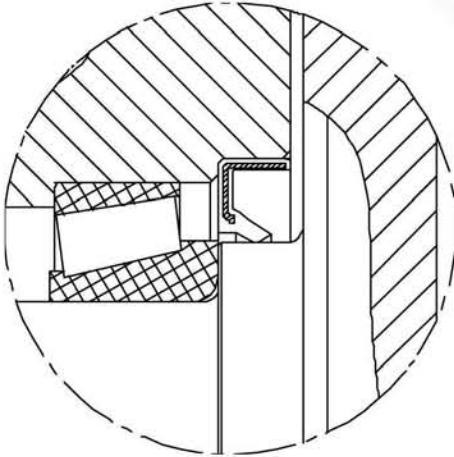

Thick Lip Grease Seal

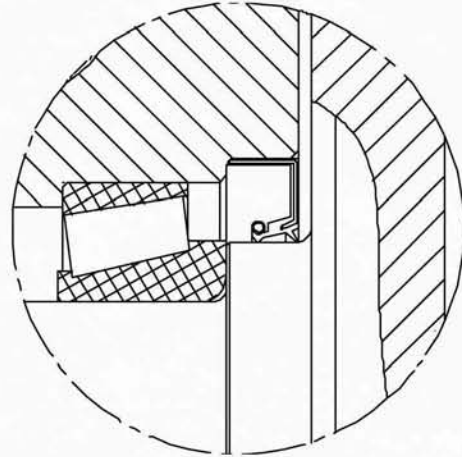

Spring Backed Oil Seal

**F. SEAL REPLACEMENT – 725-UT TOWABLE GEARBOXES.**

The seal on the “UT” unit was changed to a “Thick Lip Grease Seal” (no metal spring) which uses a New style hub with a flat bottom, starting February 1999.

The previous seal was a “Spring Backed Oil Seal” which is used in the Old style hub with a machined undercut.

Replace an Oil type seal with an Oil type seal, likewise for the Grease type seal.

The seals are to be installed as shown on the following page.

**FAILURE TO DUE SO WILL VOID THE WARRANTY.**



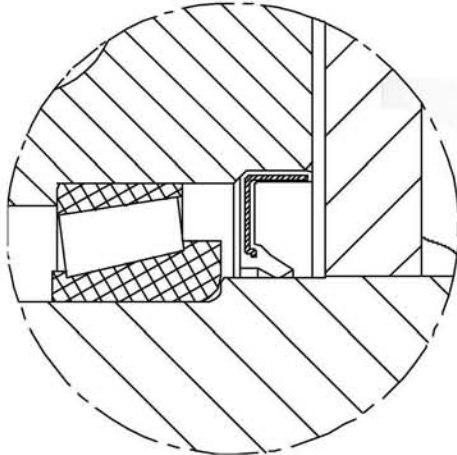

Thick Lip Grease Seal  
w/ New style Hub

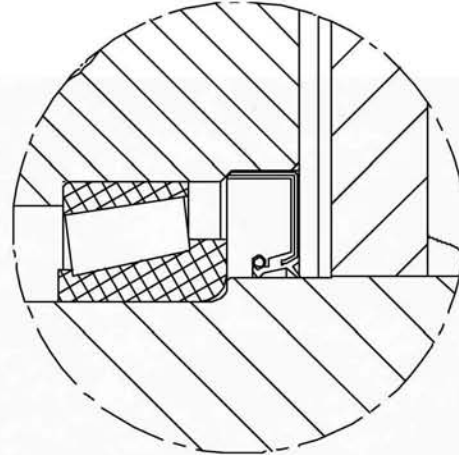

Spring Backed Oil Seal  
w/ Old style Hub

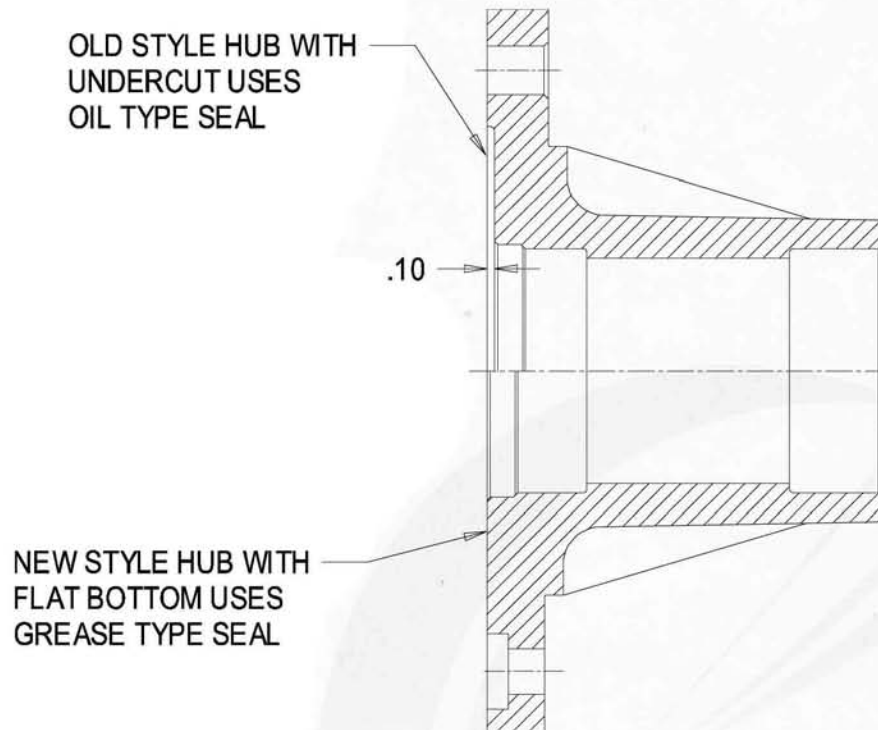

1. Drive line coupler should be inspected periodically for loose bolts and worn or cracked rubber inserts. Worn inserts should be replaced.
2. Remove any built up dirt or mud from the coupler. Mud & dirt will accelerate the wear on all components.

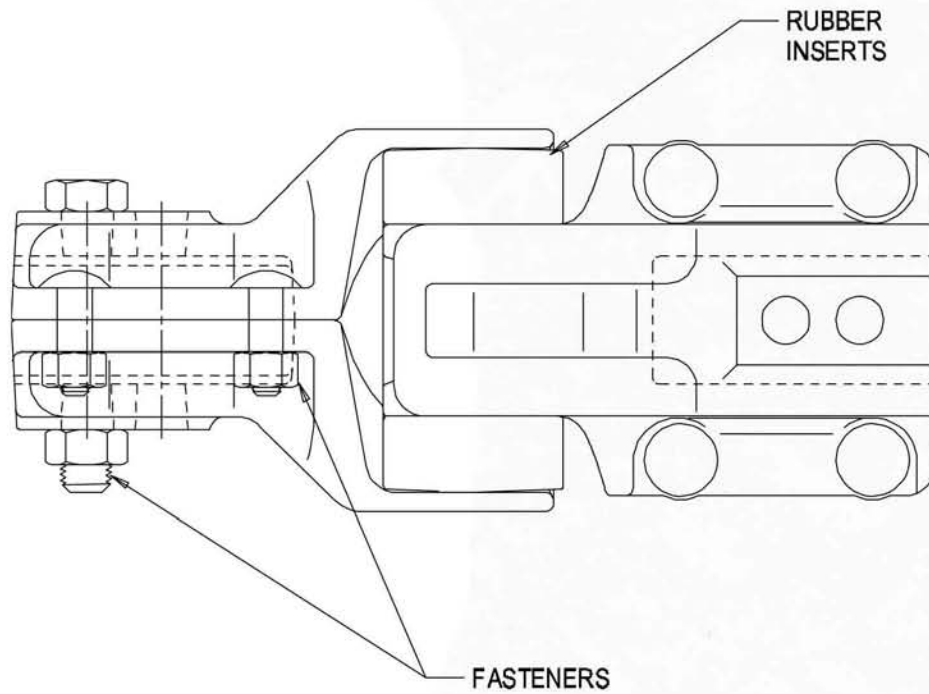

DIAGRAM CPL-1